

Container Trailer

AIRPORT TECHNOLOGY



Airport Container Trailer

Technical specifications	KCT2000-01
Loading capacity [kg]	2000
Trailer self-weight [kg]	560
Max. towing speed [km/h]	40
Wheels	4,00-4 front , 4,00-8 rear, Solid
Rollers	Ø80mm, length 380mm, galvanized, 16 pieces along 2 rows
ULD Rotation Method	Turntable 360° (90° latching)
ULD Capability	LD1, LD2, LD3, LD3/AKH
A - Overall length [mm]	3623
B - Overall length with drawbar in vertical position [mm]	2750
C - Loading platform length [mm]	1872
D - Loading platform width [mm]	1562
E - Loading platform height above ground [mm]	510
F - Rear coupling height [mm]	235
G - Wheel base [mm]	1361
H - Towing eyelet diameter [mm]	42,5

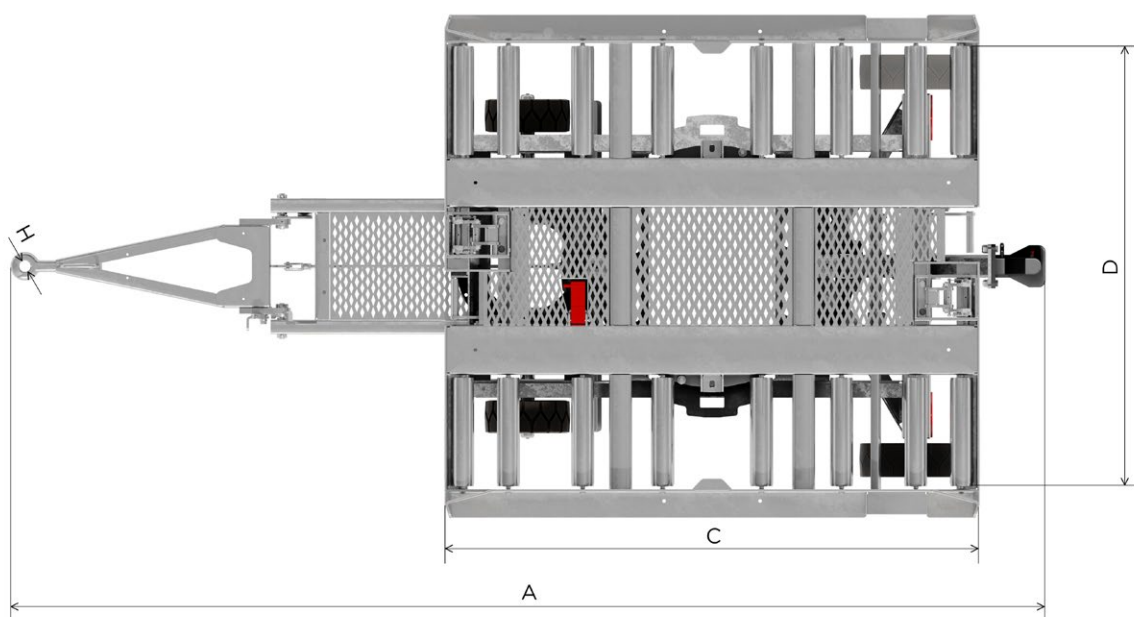
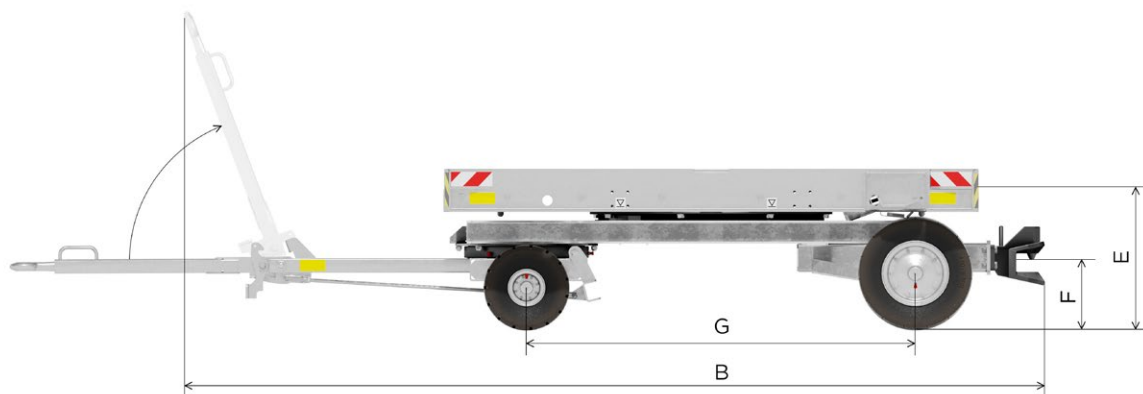

KEY FEATURES

- Durable, fully welded high-grade steel construction
- With components from renowned manufacturers (Jost, Continental, Rockinger...)
- Sophisticated foot-operated container latching
- ULD side guide rails
- Easily replaceable parts
- Low maintenance costs & long operation life
- Hitching of up to 7 trailers together
- Front wheel parking brake - activated by raising the drawbar to vertical position
- Foot-operated towbar latch release
- Hot-dip galvanized surface treatment
- Compact freight packaging (stackable)

CUSTOMIZATIONS & OPTIONS

- Alternative towing eyelets and rear couplings
- Parking brake activation also by lowering the drawbar
- Surface finish in any RAL colour
- Forklift pockets
- Other modifications upon consultation

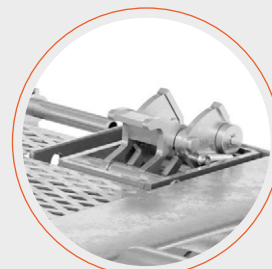

Sophisticated container latching

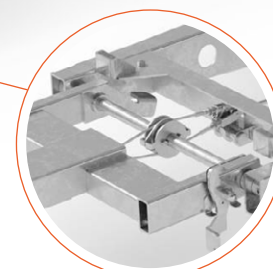
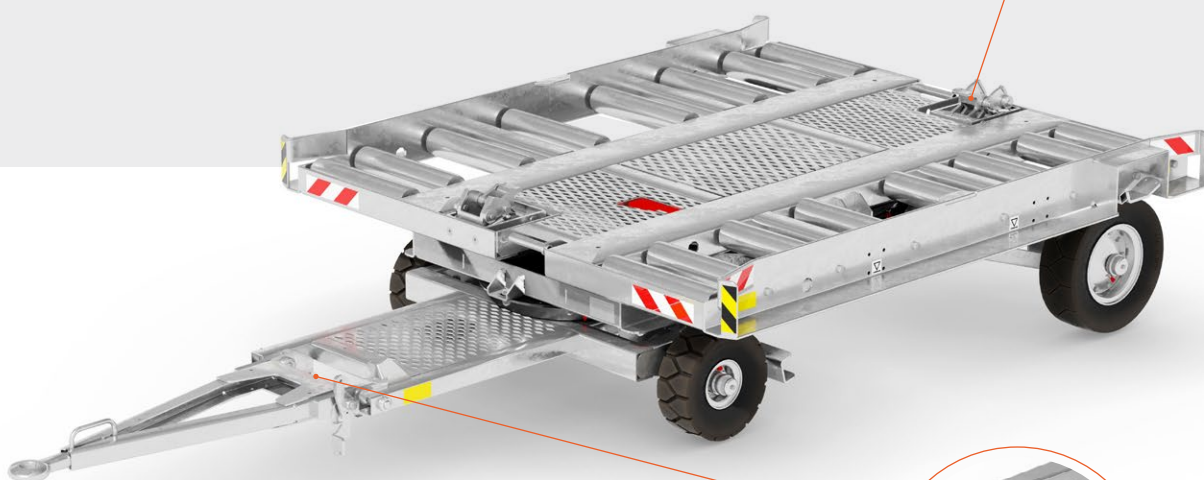

OPTION
Up & down brake activation

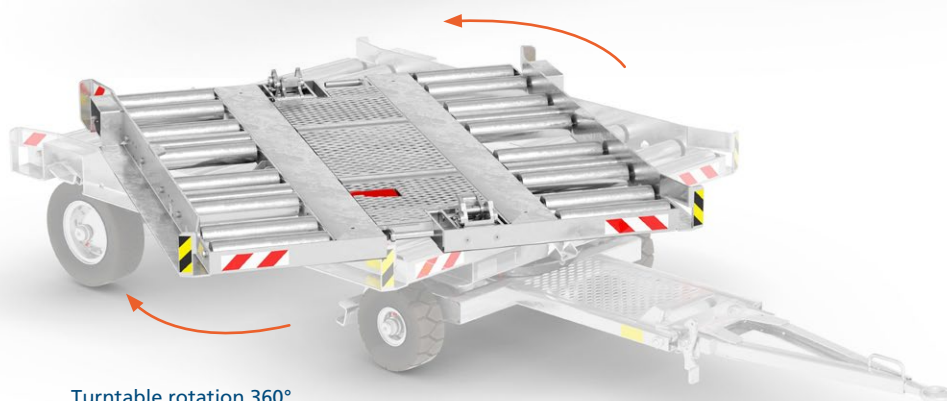

Turntable rotation 360°

Compact packaging

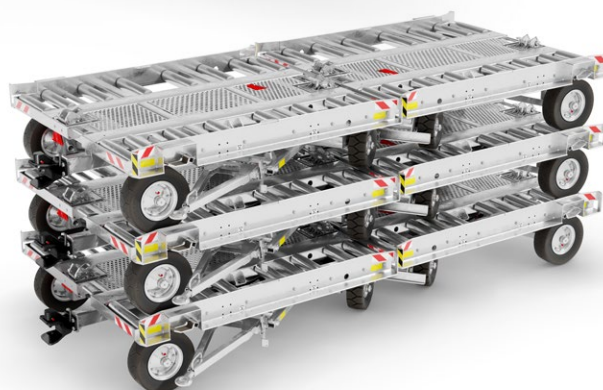

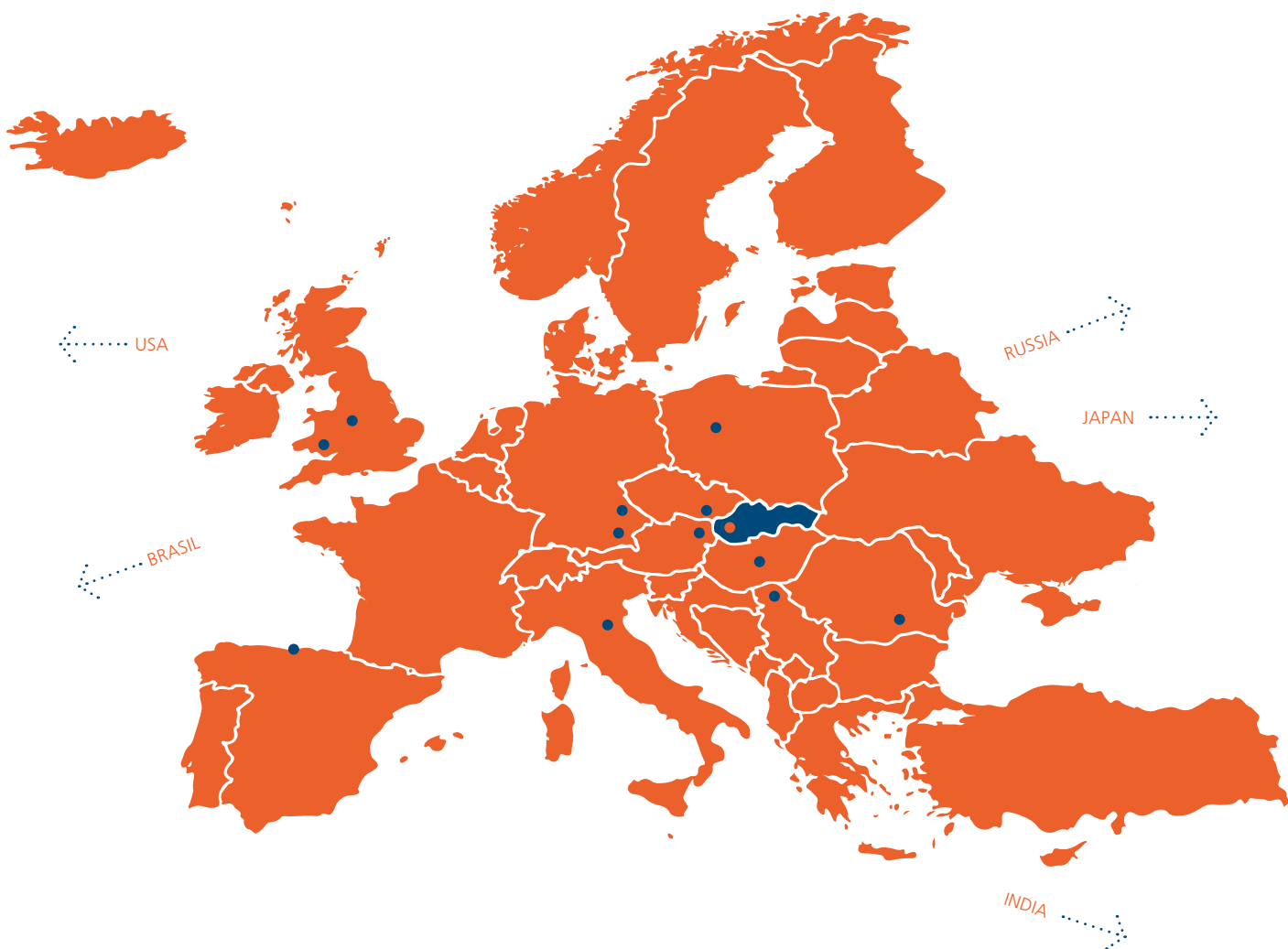

KNOTT SLOVAKIA

YOUR TAILOR-MADE MANUFACTURER

As a strategic member of the KNOTT Group we develop and produce key products in trailer technology. We are also involved in the production of sophisticated industrial brakes and have evolved into a high-quality airport ground support equipment manufacturer as well.

The ability to tailor our products to customer's needs, along with professional consulting and cooperation since the early development stages of a new product, as well as the in-house accredited testing laboratory are the main advantages of our company.

Paying attention to customer feedback, combining newest technologies with know-how based on decades-long experiences, and the implied highest product quality are characteristic for all companies within the Knott Group.

KNOTT spol. s r.o.

Dolná 142
900 01 Modra
Slovak Republic

tel.: +421 33 690 2511

e-mail: gse@knott.sk

www.knott.sk



KNOTT)))

